



Sleep well. Wherever you are.

iNAP[®] One
Sleep Therapy System

INSTRUCTIONS FOR USE

This user guide contains instructions for using the iNAP[®] One Sleep Therapy System.
Read all Instructions for Use before using the system.

Table of Contents

| | | |
|-------|---|----|
| 1 | INTRODUCTION | 3 |
| 1.1 | Description of iNAP One Sleep Therapy System | 3 |
| 1.2 | Indications for Use | 3 |
| 1.3 | Contraindications | 4 |
| 1.4 | iNAP One Sleep Therapy System Components | 4 |
| 1.4.1 | Console | 5 |
| 1.4.2 | Saliva Container | 6 |
| 1.4.3 | Oral Interface | 6 |
| 1.4.4 | Tubing Set | 6 |
| 1.5 | iNAP One Sleep Therapy System Console Icons | 7 |
| 2 | BEFORE USING THE INAP ONE SLEEP THERAPY SYSTEM | 9 |
| 2.1 | Important Safety Notes | 9 |
| 2.1.1 | Warnings (Possible Health Risks) | 9 |
| 2.1.2 | Warnings | 11 |
| 2.1.3 | Cautions | 13 |
| 2.1.4 | Precautions | 14 |
| 3 | PREPARING FOR USE INAP ONE SLEEP THERAPY SYSTEM | 15 |
| 3.1 | Check the Battery Status | 15 |
| 3.2 | Charge the System | 15 |
| 3.3 | Installation of DryPad | 16 |
| 3.4 | Connect the Oral Interface | 19 |

| | | |
|-------|--|----|
| 3.5 | Wearing the Oral Interface | 20 |
| 3.6 | iNAP Muffler | 22 |
| 4 | OPERATING INSTRUCTIONS | 23 |
| 4.1 | Starting the Treatment of the iNAP One Sleep Therapy System | 23 |
| 4.2 | Getting Used to the Treatment of the iNAP One Sleep Therapy System | 25 |
| 4.3 | Stop the Treatment of the iNAP One Sleep Therapy System | 26 |
| 4.4 | Bluetooth and App Setup Procedures | 27 |
| 5 | CLEANING, MAINTENANCE AND STORAGE | 28 |
| 5.1 | Cleaning | 28 |
| 5.1.1 | Disconnect the Tubing Set and the Container | 28 |
| 5.1.2 | Discard the DryPad | 28 |
| 5.1.3 | Clean the Container, the Oral interface and the Tubing | 29 |
| 5.1.4 | Clean the Console | 31 |
| 5.2 | Weekly Cleaning | 31 |
| 5.3 | Maintenance | 33 |
| 5.4 | Disposal | 33 |
| 6 | TROUBLESHOOTING | 34 |
| 7 | SYSTEM SPECIFICATIONS | 39 |
| 8 | GUIDANCE AND MANUFACTURER'S DECLARATION REGARDING ELECTROMAGNETIC COMPATIBILITY | 41 |
| 9 | CLINICAL DATA | 53 |
| 10 | SYMBOL | 55 |
| 11 | LIMITED WARRANTY | 57 |

1.1 Description of iNAP One Sleep Therapy System

iNAP One Sleep Therapy System is designed to treat obstructive sleep apnea (OSA) in adults. When using iNAP One Sleep Therapy System during sleep, it provides a pressure gradient within the oral cavity, and the pressure gradient pulls the tongue toward the upper palate and also pulls the soft palate forward. By moving the tongue and the soft palate in a forward direction, the patency of the upper airway near the pharynx is maintained to prevent sleep-disordered breathing. This reduces or eliminates the upper airway obstruction that causes OSA and allows each patient with OSA to enjoy deep, refreshing and uninterrupted sleep.

More importantly, OSA patients will get rest and oxygen that they need to prevent some of the health risks associated with OSA. Furthermore, the iNAP One Sleep Therapy System® is designed to provide quiet and comfortable treatment so that each user can sleep through the night without distraction. The iNAP One Sleep Therapy System continuously detects air pressure within the oral cavity and automatically adjusts the pressure gradient applied to the airway. The pressure in the oral cavity is continuously and stably maintained which prevents respiratory obstructive events that may disturb the user's sleep. In the absence of respiratory events, the user will have a good night's sleep to maximize his or her quality of life. Clinical studies conducted over a period of 28 days have demonstrated the effectiveness of the iNAP System.

1.2 Indications for Use

The iNAP One Sleep Therapy System is indicated for home use in the treatment of obstructive sleep apnea (OSA) in adults in whom positive airway pressure is not the preferred treatment choice.

1.3 Contraindications

The iNAP One Sleep Therapy System shall not be used by anyone who:

- Has Central Sleep Apnea (CSA)
- Is under the age of 21.

For use only by order of a physician.

1.4 iNAP One Sleep Therapy System Components

iNAP One Sleep Therapy System is a portable system designed to deliver a pressure gradient to the oral cavity to prevent sleep-disordered breathing.

Note Use only the power adapter supplied with the device to charge your iNAP One Sleep Therapy System.

Please check that all item listed are included in the package. Contact local dealer or Somnics Customer Service if any items are missing.



Console

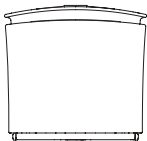

Container

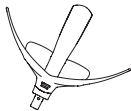

Oral Interface

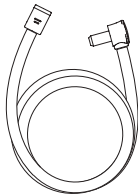

Tubing Set



DryPad

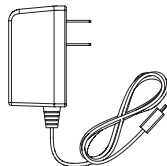

Power Adapter



Muffler
(Optional)

1.4.1 Console

Bottom of console

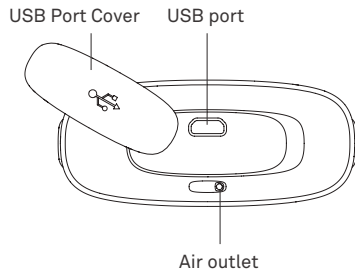
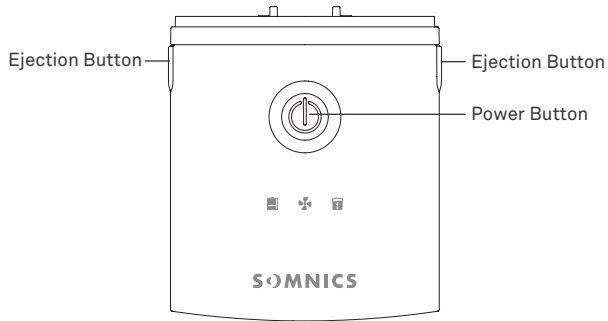

 **Caution** Blocking the air outlet of the device while in operation might lead to insufficient negative pressure.

1.4.2 Saliva Container

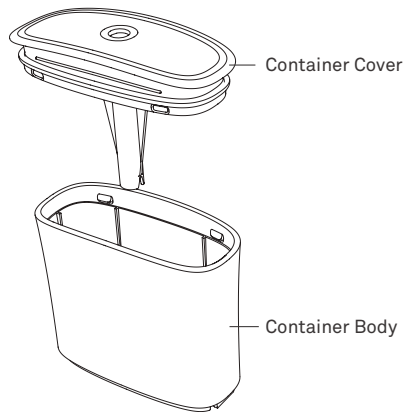



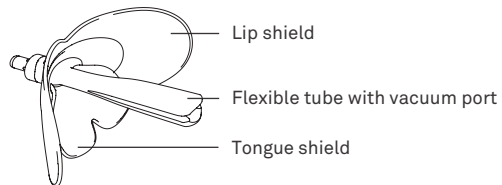



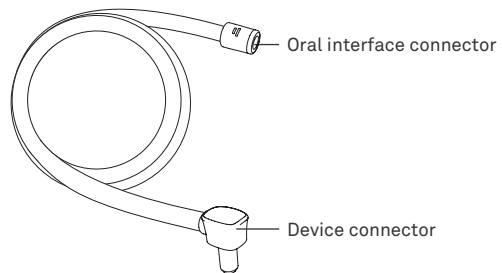

1.4.3 Oral Interface



1.4.4 Tubing Set



1.5 iNAP One Sleep Therapy System Console Icons

| Icon | Light Status | Status Indicator |
|---|--|---|
| Battery power status | | |
|  |  | Flash Low battery |
| |  | On Enough battery |
| |  | Flash Charging |
| |  | On Fully charged (with charging cable plugged in) |
| Vacuum status | | |
|  |  | Flash Pump to target vacuum |
| |  | Off Target vacuum achieved |

Container



Flash

Not installed, or
Improper installation



Off

Properly installed



On

Container full

2 BEFORE USING THE INAP ONE SLEEP THERAPY SYSTEM

2.1 Important Safety Notes

2.1.1 Warning (Possible health risks)

- Use of the iNAP One Sleep Therapy System may cause:

- Drying of the nose, mouth, or throat
- Aspiration Pneumonia
- Infection of teeth/gingiva
- Oral tissue irritation
- Hematoma / Bleeding
- Gingival or dental soreness
- Blood in mucus
- Excessive salivation
- Headache
- Soft Palate pain
- Nasal congestion
- Obstruction of oral breathing
- Chest tightness
- Soreness of the wrist
- Dental discomfort
- Tooth movement or changes in dental occlusion
- Pain or soreness to the temporomandibular joint
- Higher risk in elderly-Dementia, Parkinson's disease and those with movement disorders affecting the tongue
- Possible Bronchial infections/Upper respiratory infections/Pneumonia due to contamination in the tubing system

- Assessment of effectiveness of the iNAP One Sleep Therapy System should be conducted by your physician to ensure adequate treatment.
- If the oral interface causes prolonged discomfort, remove it and contact your physician.
- The oral interface, tubing set, saliva container and DryPad are for your use only. **DO NOT** share your oral interface, saliva container and DryPad with others.
- The long term effectiveness and safety of the iNAP One Sleep Therapy System has not been determined. Assessment of effectiveness and safety of long term use of the iNAP One Sleep Therapy System should be conducted by your physician to ensure adequate treatment.

2.1.2 Warnings

- Universal precautions should be observed whenever working with potentially contaminated components or equipment of the iNAP One Sleep Therapy System. When transporting, operating, repairing or disposing of the iNAP One Sleep Therapy System and its accessories, the risk of infectious liquids being aspirated or contamination of the device through incorrect use cannot be eliminated.
- The iNAP One Sleep Therapy System is not computed tomography (CT) or Magnetic resonance imaging (MRI) compatible. **DO NOT** put the console into the scanner range or MRI suite.
- The iNAP One Sleep Therapy System is not suitable for use in the presence of flammable anesthetic mixtures with air or with oxygen or nitrous oxide.
- The iNAP One Sleep Therapy System is not suitable for use in areas where there is danger of explosion (e.g., hyperbaric oxygen unit).
- The iNAP One Sleep Therapy System and its accessories are provided nonsterile and should not be used in a sterile field.
- Use only **Authentic Somnics accessories (container, tubing set, oral interface and DryPad)**. A different type of the tubing and the oral interface may damage the system. Always follow the instructions enclosed with the accessories.
- This system has been evaluated by biocompatibility testing. In the case of oral tissue discomfort, stop using it immediately and consult with physician.
- **DO NOT** leave long length of tubing around the top of your bed. It could twist around your head or neck to cause suffocation while you sleep. Leave some slack in the tubing when you might turn over or move around.
- Make sure the power adapter and plug are in good condition and the equipment is not damaged.
- Beware of electric shock. Keep the iNAP One Sleep Therapy System away from all sources of liquids and **DO NOT** immerse in

water or other liquids. Always unplug the device before cleaning and make sure it is dry before reconnecting.

- **DO NOT** operate the iNAP One Sleep Therapy System in an area which may cause overheating.
- **DO NOT** cover the iNAP One Sleep Therapy System with any object or material which would cause them to overheat.
- **DO NOT** leave the system on prolonged charge when not in use.
- Please use the power adapter provided by Somnics, Inc., Use of an improper power adapter might cause electric shock or damage the iNAP One Sleep Therapy System.
- Keep the iNAP One Sleep Therapy System away from hot or flammable surfaces, gases or materials.
- iNAP One Sleep Therapy System is not intended for life support.

2.1.3 Cautions

- Physician should consider the medical history and condition of the patient, including but not limited to, history of asthma, sinusitis, nasal obstruction, breathing, or respiratory disorders or other relevant health problems, and refer the patient to the appropriate health care provider before prescribing this system.
- In the event of a power failure or console malfunction, remove the oral interface. The system will not provide effective therapy if the console is not powered on or functioning properly.
- Patients should have documented obstructive sleep apnea.
- Adequacy of nasal patency should be assessed.
- Patients who have obstructed nasal passages, as evidenced by the inability to breathe through the nose with the mouth closed, should not use iNAP One Sleep Therapy System.
- iNAP One Sleep Therapy System effectiveness has not been assessed in patients with nighttime mouth breathing.



2.1.4 Precautions

- Check the system regularly when in use, for pump operation, battery status, interface integrity and type/amount of exudates.
- Keep the iNAP One Sleep Therapy System away from all sources of liquids and **DO NOT** immerse in water or other liquids.
- **DO NOT** expose the system and its accessories to open flames, or other sources of ignition, such as cigarettes, etc.
- **DO NOT** store the system in direct sunlight.
- Make sure the system is clean and dry prior to storage.
- This system is for **SINGLE PERSON USE** only. Use of the oral interface or saliva container for more than one patient may result in cross contamination that may lead to infection.
- If you put the system on the floor, make sure that the area is free from dust and clear of bedding, clothes or other objects that could block the air outlet.
- Make sure the area around the system is dry and clean.
- Please keep small parts and accessories away from children and pets at all time to avoid any risk of the parts been swallowed.
- Contact Somnics Customer Service if there are any questions during setup, use or maintenance.
- **DO NOT** use bleach, chlorine, alcohol, or aromatic-based solutions, moisturizing or antibacterial soaps, scented oils, or phenol-based solutions to clean the system. These solutions may create a shock hazard, cause damage and reduce the life of these items.
- Retain the original product literature for future reference.

3 PREPARING FOR USE IN AP ONE SLEEP THERAPY SYSTEM

3.1 Check the Battery Status

Press the power button to check the battery status.

| Battery status | Status Indicator | Suggestion |
|---|---|-------------------------------|
|  |  On | Enough battery |
| |  Flash | Low battery Please charge! |

3.2 Charge the System

Open the USB port cover and connect the micro USB plug of the power adapter into the port of the console, then plug the power adapter into a standard wall outlet (100-240 Vac).

Note A lithium-ion battery embedded in the console is not replaceable. Please charge more than 8 hours for the first time.

 **Caution DO NOT** use the system when charging.
Use ONLY Authentic Somnics accessory to charge the console.

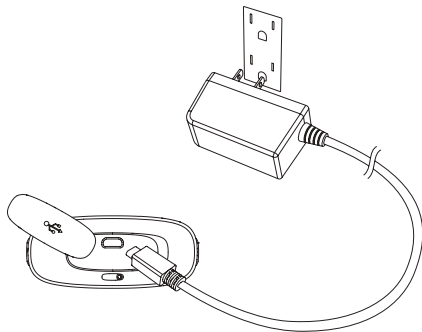

3.3 Installation of DryPad

1. Disconnect the console and the container.

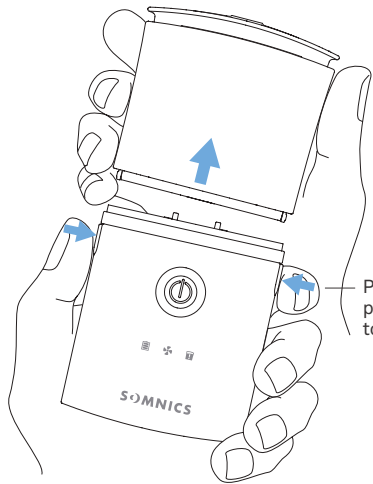

Press the ejection button, then pull the saliva container upward to separate it from console.

2. Open the Container

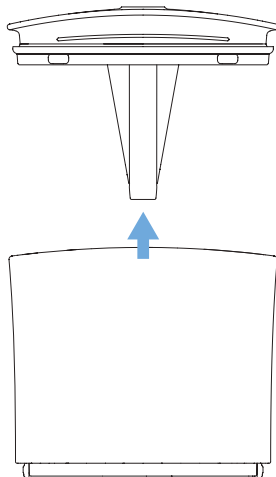

3. Squeeze the sides of DryPad then insert the center tube of the container cover into the opened iNAP DryPad.

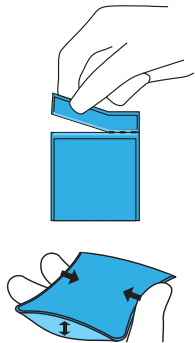

Tear (if applicable) the dotted line of DryPad and squeeze to open it

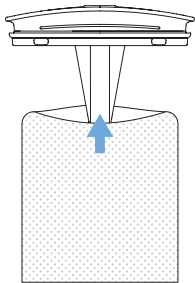

Squeeze the side of DryPad

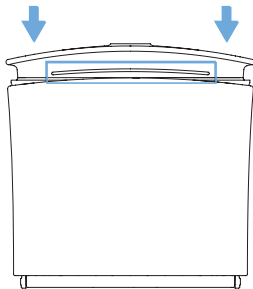

Make the position of marking line under the container body

4. Put the cover on the body of the container and make sure there is no gap between the container cover and the container body.

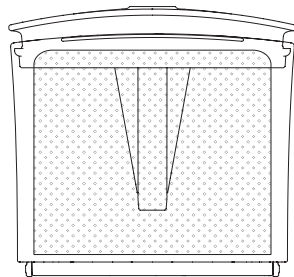

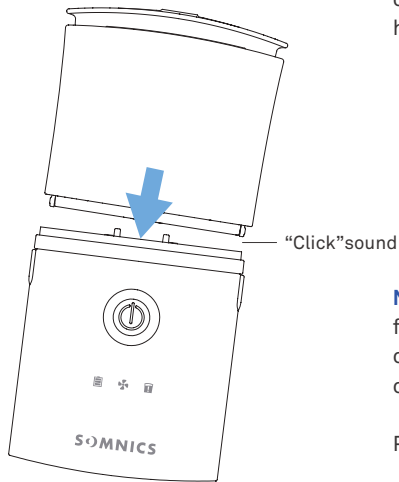

5. Connect the console and container make sure that you hear the click sound

Note If the container icon is flashing, please reconfirm the connection condition of the container and the console.

Please refer to section 1.5

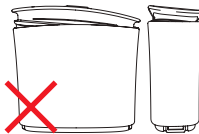

! **Caution** Wrong container cover position

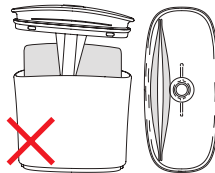

! **Caution** Wrong DryPad position

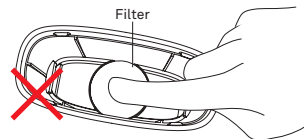

! **Caution** DO NOT contact the filter

3.4 Connect the Oral Interface

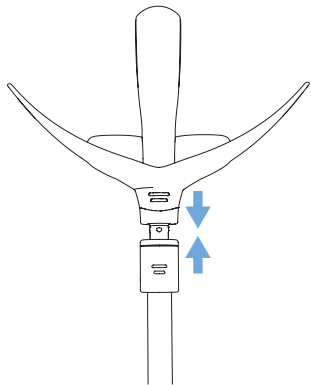

1. Connect the oral interface with the tubing.

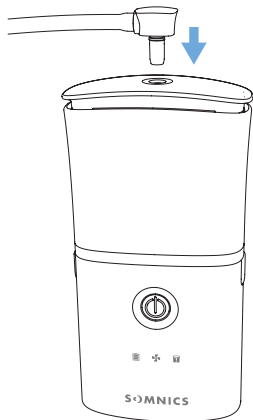

2. Connect the tubing to the console.

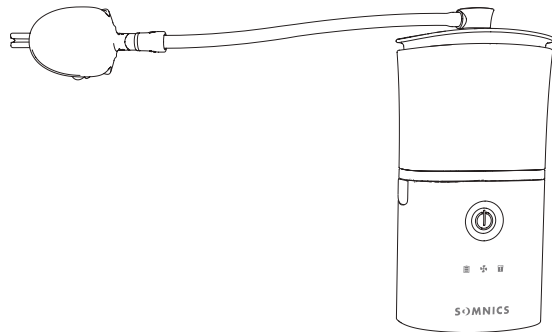

3. Ready to use.

3.5 Wearing the Oral Interface

If you find any possible defect that you think will impact the performance of the system, **DO NOT** use the oral interface. Contact Somnics Customer Service.

Note Wash the oral interface with warm water before using it the first time.

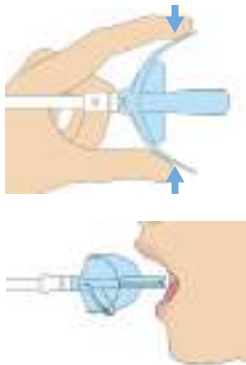

Insert the oral interface in your mouth by squeezing the lip shield appropriately.



Make sure the lip shield is located between the front of the teeth and behind the lips.

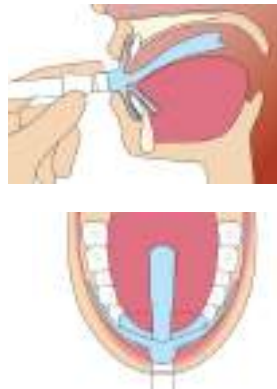

Keep the lip shield and the flexible tube in your mouth, then have the tongue rest on the tongue shield.

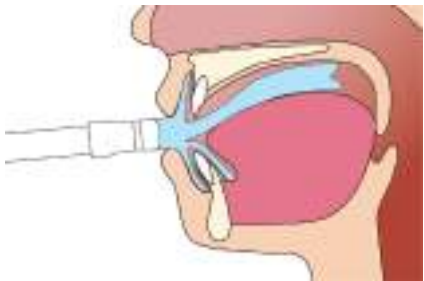

Close your mouth and get ready to start the treatment of the iNAP One Sleep Therapy System.

Note Please put the oral interface ONLY in your mouth.

Note DO NOT chew on or swallow the oral interface.

21 **Note** DO NOT wear the oral interface while eating or drinking.

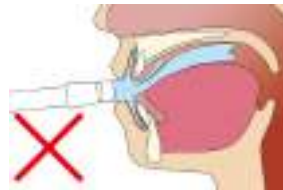

⚠ **Caution DO NOT** put the tongue shield on the tongue inside your mouth.



⚠ **Caution DO NOT** put lip shield outside the lips. What's the tongue shield? Please refer to section 1.4.3

3.6 iNAP Muffler

It is an accessory dedicated to use with iNAP One Sleep Therapy System. Please read this instruction thoroughly before use.

Note The sponge inside is part of the muffler. Do not remove the sponge from the muffler.

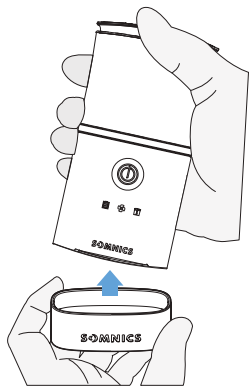

1. Hold the muffler tight and put iNAP Console into the muffler.

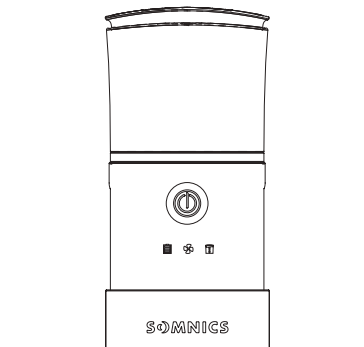

2. Make sure the connection between iNAP Console and the muffler is stable.

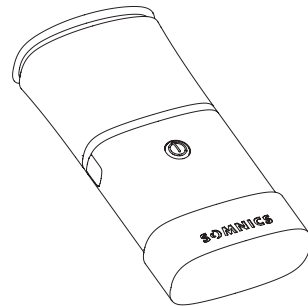

3. Place iNAP Console flat and enjoy the treatment.

4 OPERATING INSTRUCTIONS

4.1 Starting the Treatment of the iNAP One Sleep Therapy System

- Press and hold the power button for over 2 seconds to turn on the console. The console runs a system check and all icons flash once. After system check battery icon  remains solid green

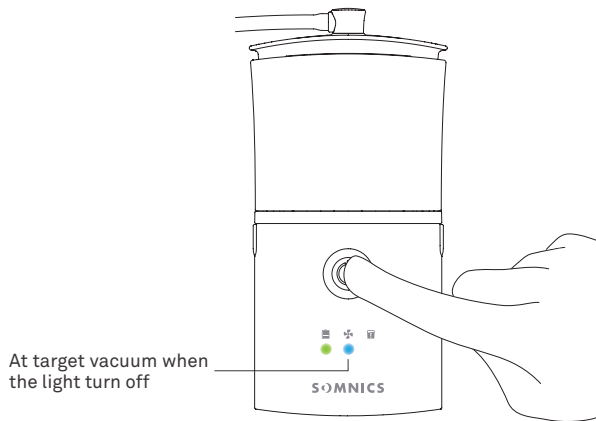

Note Icons dim after 30 seconds of treatment started. Press the power button again to activate and illuminate the icons.

Note If the three icons keep flashing, there is a problem with your console. Press and hold the power button for at least 7 seconds to reset it. Turn the console ON again, if the lights keep on flashing, **DO NOT** use the system. Contact Somnics Customer Service.

- Wait for the vacuum level on the console to reach the target vacuum.
Wait for the light of the vacuum icon turns from blue to OFF. If the light keeps flashing, it means the console is in the process of increasing vacuum pressure to its target level. That can take about 10-30 seconds. The vacuum pumping process can occur during a system check during the treatment period of the iNAP One Sleep Therapy System.

If you have difficulty maintaining the target vacuum pressure during the treatment, please refer to the troubleshooting guide for potential causes and their solutions. If the problem can not be resolved, contact iNAP One Sleep Therapy System Customer Service.

Note If your console is still pumping after 30 seconds, please recheck the installation of tubing and make sure the tubing is properly connected.

Note The vacuum level is fixed; you can not adjust the pressure level of the console.

- Continue breathing through your nose and lie down to sleep.



Note Make sure the tubing will not get tangled or kinked while you sleep. Leave some slack in the tubing when you might turn over or move around.

Note **DO NOT** use the system while charging.

4.2 Getting Used to the Treatment of the iNAP One Sleep Therapy System

Anything new, including the iNAP One Sleep Therapy System, takes time to get used to. You may not feel comfortable with the oral interface in your mouth when you first start using the iNAP One Sleep Therapy System.

Here are some tips to help familiarize you with the system more quickly:

- Try to wear the oral interface of iNAP One Sleep Therapy System, while switching the console "On" or "Off." Practice breathing through your nose with the oral interface in your mouth for an hour or so while watching television, reading or performing some other sitting activity.
- Try to put your tongue on the tongue shield and make a sucking motion. The vacuum will be achieved easily and hold your tongue in place.
- Try to use the iNAP One Sleep Therapy System during your nap time as well.
- Try to use the iNAP One Sleep Therapy System for about 3-4 hours of sleep each night when you first use the iNAP One Sleep Therapy System.
- Use the iNAP One Sleep Therapy System® for an entire night once you get used to it.

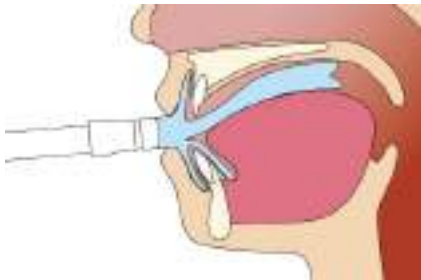

4.3 Stop the Treatment of the iNAP One Sleep Therapy System

Take out the oral interface from mouth, then press the power button on the console for at least 2 seconds to turn the device OFF. The oral interface and the container should be cleaned after each use.

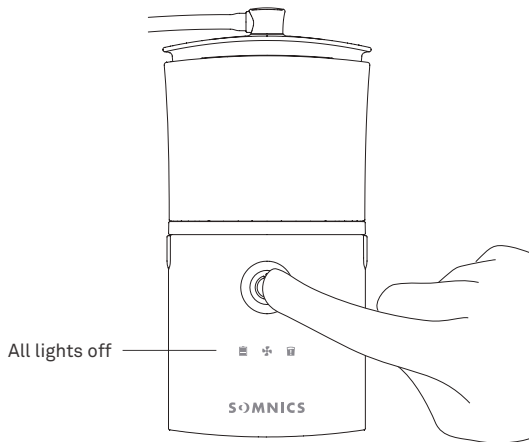

Note In case you need to leave bed during night sleep, press and hold the power button to turn OFF the console. Remove the oral interface and put it into the Oral Interface Box (sold separately) or a clean container such as mug, bowl...etc. Resume the treatment when return.

4.4 Bluetooth and App Setup Procedures

Somnics provides a mobile app for you to track your daily progress. You may download the app via Google Play (Android) or App Store (iOS).

1. Click iNAP App icon on the mobile device.
2. Turn on iNAP One Sleep Therapy System.
3. Click Scan of App on the mobile device. A device list is shown after a few seconds.
4. Match the serial number on the console and tap the corresponding serial number to connect.
5. Follow instructions to complete app setup.

Note The bluetooth low energy module used in iNAP One Sleep Therapy System is Bluetooth® Smart 4.2 BLE compliant. For more information about the App, please contact Somnics Customer Services info@somnics.com.

5 CLEANING, MAINTENANCE AND STORAGE

Clean the oral interface and the container after each use.

5.1 Cleaning

5.1.1 Disconnect the Tubing Set and the Container

Remove the oral interface from your mouth and disconnect the device connector from the container cover.

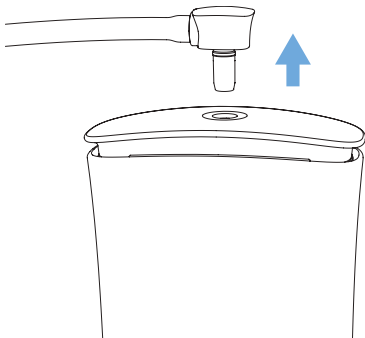

5.1.2 Discard the DryPad

Remove the used DryPad from the container and discard it.

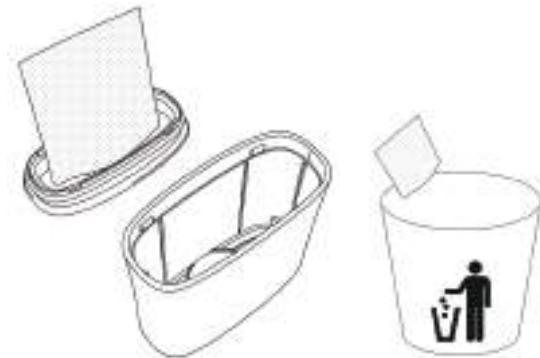

5.1.3 Clean the Container, the Oral interface and the Tubing

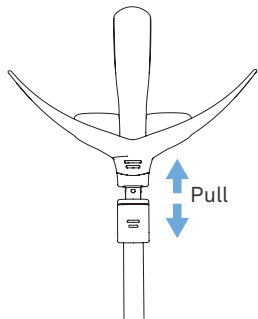

- Disconnect the oral interface from the connector.

• Oral Interface Cleaning

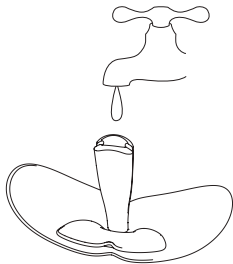

- Rinse and gently rub the oral interface with warm water.

• iNAP Tubing Set Cleaning

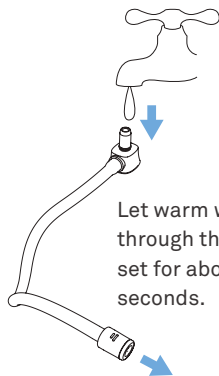

Let warm water flow through the tubing set for about 30 seconds.

• Container Cleaning

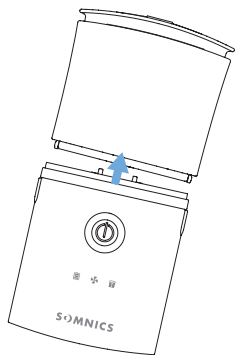

Note Both the oral interface and tubing set should be cleaned daily by washing them in warm mild soap or diluted dishwashing detergent water. Any soap residue should be removed from the oral interface and tubing by completely rinsing them in warm water.

Note You can use a soft brush or a sponge to gently scrub the surface of the oral interface.

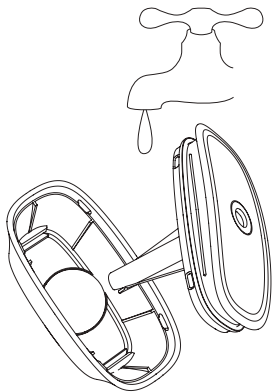

Note If the container body is not wetted by saliva, you can use a soft brush or a sponge to gently scrub the surface of the container.

Note Rinse the container with warm water. **DO NOT** touch or brush the filter inside the container body.

Note Shake off excessive water, wipe dry the exterior surface of saliva container and tubing set with clean cloth.



⚠ Caution DO NOT wash, touch or brush the filter on the bottom of the container body. Dry the filter when it has been wetted by saliva or water.

Note DO NOT clean the oral interface in the dishwasher.

Note DO NOT clean the oral interface with toothpaste.

5.1.4 Clean the Console

The console does not require cleaning after each use, and it can be wiped when necessary with a damp towel.

Note Keep the iNAP One Sleep Therapy System away from all sources of liquids and **DO NOT** immerse in water or other liquids.

5.2 Weekly Cleaning



- ① Clean the oral interface, tubing set, and container daily. Please refer to the recommended daily cleaning steps.
- ② Connect the oral interface, tubing, container, and the iNAP console.
- ③ Prepare a cup of appropriate capacity and immerse 150mL of lukewarm drinking water.

Note **DO NOT** use hot water with a temperature greater than 40 °C/ 104 °F.

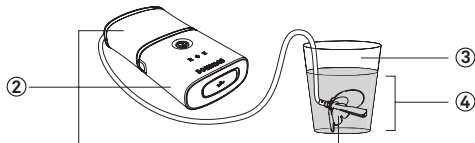

- ④ Place the oral interface inside the cup. The oral interface and its connector must be entirely submerged underwater.
- ⑤ Soak the oral interface for 15 minutes to clean the oral interface.

Note Please **DO NOT** soak your oral interface, tubing, and saliva container in the cleaning solution overnight. Prolonged immersion might cause damage to the filter.

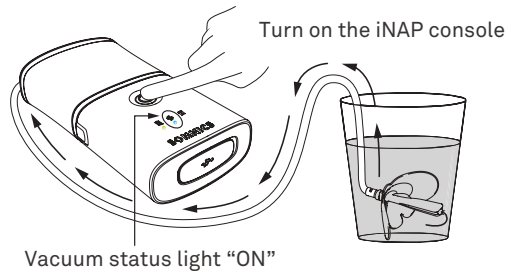

⑥ Lay down the container and turn on the iNAP console. At this time, the battery power light will be solid green  , and the vacuum status light will be flash blue  . The negative pressure will draw the water through the tubing and into saliva container.



⑦ When the container is full, the clean saliva container light will be solid orange  , and the vacuum status light will become dim  , at the point turn off the iNAP console and wait 15 minutes to clean saliva container and tubing.

⑧ Disconnect the console and clean the oral interface, tubing and container by washing them in warm mild soap or diluted dishwashing detergent water. And remove any soap residue from the oral interface and tubing by completely rinsing the them in warm water.

⑨ Dry off the oral interface, tubing, and container.

5.3 Maintenance

- Console: iNAP One Sleep Therapy System is designed to provide accurate pressure without the need of additional calibration by the end user. No routine maintenance is required if the system is used in accordance with the user manual.
- Accessory: Clean the oral interface, the tubing set, and the container after each use. Replace the oral interface and the tubing every 3 months; replace the container every 6 months or sooner if necessary. Contact iNAP One Sleep Therapy System Customer Service, if you have any questions on how to order or get consumables for the system.

 **Caution** DO NOT modify the iNAP One Sleep Therapy System without authorization from the manufacturer.















Note Check the console before use and clean it if necessary. If the console has not been used for a long time, please recharge the battery before use.



Note When traveling, be aware of the voltage differences in different regions. The iNAP One Sleep Therapy System is ONLY compatible with electrical outlets from 100-240Vac (50~60Hz).



5.4 Disposal





At the end of the product life cycle, dispose the iNAP One Sleep Therapy System according to the local regulation of disposal of bio-contaminated electronic devices.

6 TROUBLESHOOTING

| Problem | Possible Cause | Light Status | Solution |
|--|--|--|---|
| Cannot feel vacuum in Mouth | Incorrect connection of oral interface and tubing |    | Re-connect oral interface and tube and make sure hear the “click sound”. |
| | Incorrect connection of saliva container and tubing |    | Re-connect container connector and saliva container cover and make sure hear the “click sound”. |
| | Incorrect installation of the body and cover of saliva container | OR  | Close the container cover and body again and make sure the marking line of saliva container cover is at the right position. |
| | Tube blocked |    | Make sure water flow can pass through tube; if not, replace with a new tube. |
| Oral interface tube with vacuum port blocked |    OR  | Clean the oral interface, and make sure water flow can pass through vacuum port. If water cannot flow through, replace a new oral interface. | |

| Problem | Possible Cause | Light Status | Solution |
|-----------------------------|--------------------------------|---|---|
| Cannot feel vacuum in Mouth | Saliva container cover blocked | In the situation of blockage, Indicators might appear normal. | Clean the hole of saliva container cover or replace a new saliva container. |
| | Saliva container body blocked |   OR  | <ol style="list-style-type: none"> 1. Check if the filter in saliva container is blocked. 2. Make sure the connection between console and saliva container is not blocked. 3. If blocked, remove the obstruction, or clean it with a damp swab. Rest for 30 minutes before power on again. |
| | Saliva container full | | <ol style="list-style-type: none"> 1. Remove and replace DryPad. 2. Empty the container. |
| | Inlet port of console blocked | | <ol style="list-style-type: none"> 1. Check if the inlet port on the console is free from obstructions. 2. If blocked, remove the obstruction, or clean it with damp swab. Rest for 30 minutes before power on again. 3. If the problem persists, please contact Somnics Customer Service. |

| Problem | Possible Cause | Light Status | Solution |
|--------------------------------------|---|--|--|
| <p>Cannot maintain target vacuum</p> | <p>Improper oral interface placement</p> | | <p>Make sure the lip shield and flexible tube with vacuum port in your mouth, and put the tongue rest on the tongue shield.</p> |
| | <p>Damage on oral interface, saliva container or tubing</p> | | <p>Check if there is any visible damage on tubing, oral interface or saliva container. Replace the damaged part if found. In the case of no visible damage found, contact Somnics Customer Service for help.</p> |
| <p>Console does not power ON</p> | <p>Improper saliva container assembly with console</p> |  | <p>Separate saliva container from the console and assemble again. Make sure a "click" is heard when assembling.</p> |
| | <p>Low battery</p> |  | <p>Check battery status by pressing power button. If battery indicator flashes for 2 seconds, recharge the console using adapter comes with the package. Note: Use ONLY Somnics authentic adapter to charge.</p> |

| Problem | Possible Cause | Light Status | Solution |
|---|-----------------------------------|--|---|
| Console does not power ON | System reboot required |   | <ol style="list-style-type: none"> 1. Press and hold the power button for at least 7 seconds to reset the console. 2. Turn on the console again. If the problem persists, please contact Somnics Customer Service for help. |
| | Charging |  | Check if the charging plug is still connected to the console. Unplug it and try again. iNAP One Sleep Therapy System is designed not to be used during charging. |
| Console is not charging | The battery is fully charged |   | Unplug the USB plug, cover the USB port and try again. |
| | Use the unqualified power adapter | | Use ONLY Somnics authentic adapter to charge. |
| Oral interface does not fit comfortably | Improper oral interface placement | NA | <ol style="list-style-type: none"> 1. Follow the instructions to place the interface in the mouth for proper oral interface placement. 2. If oral interface still does not fit comfortably, contact your physician. |

| Problem | Possible Cause | Light Status | Solution |
|--|---|--------------|---|
| Pain, soreness or physically change to your teeth or gum | Oral interface is improperly worn. Prolonged use of oral interface | NA | Stop using the system immediately. Contact your physician. |
| Console is noisy | The console is close to ears | NA | Place the console farther from the head. |
| | Vibrations from floor or other surface | NA | <ol style="list-style-type: none"> 1. Make sure console is placed on a level surface. 2. If placed on the floor, move console to a carpet or carpeted or covered surface. |

7 SYSTEM SPECIFICATIONS

| | |
|------------------------------------|--|
| Product Name | iNAP One Sleep Therapy System |
| Dimensions (Console and Container) | 5.98" x 3.14" x 1.41"(152 x 80 x 36mm) |
| Weight (Console and Container) | 0.47 lbs (210g) |
| Warranty/Life time (Console) | 2 years |
| Battery Run Life | Approximately 4 nights (8 hours per night) |
| Bluetooth Module | Frequency Range: 2.402 GHz - 2.480 GHz Transmit Power: Class 2 output power (0 dBm typical, +2 dBm maximum) |
| Power Adapter | Input: 100-240 Vac, 50~60Hz Output: 5.0Vdc, 0~2.0A |
| Storage/Transport | -20°C ~ 50°C 15 ~ 93% (non condensing) |

| | | | |
|---|-------------------------------|---------------|----------------|
| Product Name | iNAP One Sleep Therapy System | | |
| Operating Range | 5°C ~ 40°C | | |
| | 15 ~ 93% (non condensing) | | |
| Operation/Storage Atmospheric pressure: | 700hPa ~ 1060hPa | | |
| Operating Altitude | Up to 8,858ft (2700m) | | |
| Vacuum Setting / Accuracy | 54 cmH2O / ±10% | | |
| Ingress Protection | IP22 | | |
| Patient Protection | Type BF | | |
| Compliance | IEC 60601-1 | IEC 60601-1-2 | IEC 60601-1-11 |

8 GUIDANCE AND MANUFACTURER'S DECLARATION REGARDING ELECTROMAGNETIC COMPATIBILITY

Manufacturer's declaration-electromagnetic emissions

The iNAP One is intended for use in the electromagnetic environment (for home healthcare) specified below. The customer or the user of the iNAP One should assure that it is used in such an environment.

| Emission test | Compliance | Electromagnetic environment-guidance (for home healthcare environment) |
|---|----------------|---|
| RF emissions CISPR 11 | Group 1 | The iNAP One uses RF energy only for its internal function. Therefore, its RF emissions are very low and are not likely to cause any interference with nearby electronic equipment. |
| RF emissions CISPR 11 | Class B | The iNAP One is suitable for use in all establishments, including domestic establishments and those directly connected to the public low-voltage power supply network that supplies buildings used for domestic purposes. |
| Harmonic emissions IEC 61000-3-2 | Not applicable | |
| Voltage fluctuations /flicker emissions IEC 61000-3-3 | Not applicable | |

Manufacturer's declaration-electromagnetic immunity

The iNAP One is intended for use in the electromagnetic environment (for home healthcare) specified below.

The customer or the user of the iNAP One should assure that it is used in such an environment.

| Immunity test | IEC 60601 test level | Compliance level | Electromagnetic environment-guidance (for home healthcare environment) |
|---|--|--|--|
| Electrostatic discharge (ESD) IEC 61000-4-2 | Contact:±8 kV Air±2 kV, ±4 kV, ±8 kV, ±15 kV | Contact:±8 kV Air±2 kV, ±4 kV, ±8 kV, ±15 kV | Floors should be wood, concrete or ceramic tile. If floors are covered with synthetic material, the relative humidity should be at least 30% |
| Electrical fast transient/ burst IEC 61000-4-4 | + 2kV for power supply lines + 1kV for input/ output lines | Not applicable Not applicable | Main power quality should be that of a typical home healthcare environment. |
| Surge IEC 61000-4-5 | + 0.5kV, +1kV line(s) to line(s) + 0.5kV, +1kV,+ 2kV line(s) to earth | Not applicable Not applicable | Mains power quality should be that of a typical home healthcare environment. |

Manufacturer's declaration-electromagnetic immunity

The iNAP One is intended for use in the electromagnetic environment (for home healthcare) specified below.

The customer or the user of the iNAP One should assure that it is used in such an environment.

| Immunity test | IEC 60601 test level | Compliance level | Electromagnetic environment-guidance (for home healthcare environment) |
|---|---|--|---|
| Voltage Dips, short interruptions and voltage variations on power supply input lines IEC 61000-4-11 | Voltage dips: 0 % U_T ; 0,5 cycle | Voltage dips: Not applicable | Main power quality should be that of a typical home healthcare environment. If the user of the iNAP One requires continued operation during power interruptions, it is recommended that the iNAP One be powered from an uninterruptible power supply or a battery. |
| | 0 % U_T ; 1 cycle | Not applicable | |
| | 70 % U_T ; 25/30 cycles | Not applicable | |
| | Voltage interruptions: 0 % U_T ; 250/300 cycle | Voltage interruptions: Not applicable | |
| Power frequency(50, 60 Hz) magnetic field IEC 61000-4-8 | 30 A/m 50 Hz or 60 Hz | 30 A/m 50 Hz and 60 Hz | The iNAP One power frequency magnetic fields should be at levels characteristic of a typical location in a typical home healthcare environment. |

NOTE U_T is the a.c. mains voltage prior to application of the test level.

Manufacturer's declaration-electromagnetic immunity

The iNAP One is intended for use in the electromagnetic environment (for home healthcare) specified below. The customer or the user of the iNAP One should assure that is used in such and environment.

| Immunity test | IEC 60601 test level | Compliance level | Electromagnetic environment-guidance |
|-------------------------------|---|---|--|
| Conducted RF IEC 61000-4-6 | 3 Vrms: 0,15 MHz – 80 MHz 6 Vrms: in ISM and amateur radio bands between 0,15 MHz and 80 MHz 80 % AM at 1 kHz | 3 Vrms: 0,15 MHz – 80 MHz 6 Vrms: in ISM and amateur radio bands between 0,15 MHz and 80 MHz 80 % AM at 1 kHz | Portable and mobile RF communications equipment should be used no closer to any part of the iNAP One including cables, than the recommended separation distance calculated from the equation applicable to the frequency of the transmitter. |
| Radiated RF IEC 61000-4-3 | 10 V/m 80 MHz – 2,7 GHz 80 % AM at 1 kHz | 10 V/m 80 MHz – 2,7 GHz 80 % AM at 1 kHz | Recommended separation distance: $d = 1,2 \sqrt{P}$ $d = 1,2 \sqrt{P}$ 80MHz to 800 MHz $d = 2,3 \sqrt{P}$ 800MHz to 2,7 GHz |

Where P is the maximum output power rating of the transmitter in watts (W) according to the transmitter manufacturer and d is the recommended separation distance in meter (m).

| Immunity test | IEC 60601 test level | Compliance level | Electromagnetic environment-guidance |
|------------------------------|--|--|---|
| Radiated RF IEC 61000-4-3 | 10 V/m 80 MHz – 2,7 GHz 80 % AM at 1 kHz | 10 V/m 80 MHz – 2,7 GHz 80 % AM at 1 kHz | Interference may occur in the vicinity of equipment marked with the following symbol:  |

NOTE1 At 80 MHz and 800 MHz, the higher frequency range applies.

NOTE2 These guidelines may not apply in all situations. Electromagnetic propagation is affected by absorption and reflection from structures, objects and people.

NOTE3 Testing indicated that use of RFID readers at 870-960 or 2450MHz near the iNAP may interfere with the Bluetooth connection that supports the iNAP mobile app.

Recommended separation distance between portable and mobile RF communications equipment and the iNAP One

The iNAP One is intended for use in an electromagnetic environment (for home healthcare) in which radiated RF disturbances are controlled. The customer or the user of the iNAP One can help prevent electromagnetic interference by maintaining a minimum distance between portable and mobile RF communications equipment (transmitters) and the iNAP One as recommended below, according to the maximum output power of the communications equipment.

| Rated maximum output power of transmitter W | Separation distance according to frequency of transmitter m | | |
|--|--|--|---|
| | 150 kHz to 80 MHz $d = 1,2\sqrt{P}$ | 80 MHz to 800 MHz $d = 1,2\sqrt{P}$ | 800 MHz to 2,5 GHz $d = 2,3\sqrt{P}$ |
| 0,01 | N/A | 0,12 | 0,23 |
| 0,1 | N/A | 0,38 | 0,73 |
| 1 | N/A | 1,2 | 2,3 |
| 10 | N/A | 3,8 | 7,3 |
| 100 | N/A | 12 | 23 |

For transmitters rated at a maximum output power not listed above, the recommended separation distance d in meters (m) can be estimated using the equation applicable to the frequency of the transmitter, where p is the maximum output power rating of the transmitter in watts (W) according to the transmitter manufacturer.

NOTE1 At 80 MHz and 800 MHz, the separation distance for the higher frequency range applies.

NOTE2 These guidelines may not apply in all situations. Electromagnetic propagation is affected by absorption and reflection from structures, objects and people.

Manufacturer's declaration-electromagnetic immunity

Test specifications for ENCLOSURE PORT IMMUNITY to RF wireless communications equipment

The iNAP One is intended for use in the electromagnetic environment (for home healthcare) specified below.

The customer or the user of the iNAP One should assure that it is used in such an environment.

| Test frequency (MHz) | Band ^{a)} (MHz) | Service ^{a)} | Modulation ^{b)} | Maximum power (W) | Distance (m) | IMMUNITY TEST LEVEL (V/m) | Compliance LEVEL (V/m) (for home healthcare) |
|----------------------|--------------------------|-----------------------|--|-------------------|--------------|---------------------------|--|
| 385 | 380 – 390 | TETRA 400 | Pulse modulation ^{b)} 18 Hz | 1,8 | 0,3 | 27 | 27 |
| 450 | 430 – 470 | GMRS 460, FRS 460 | FM ^{c)} ±5 kHz deviation 1 kHz sine | 2 | 0,3 | 28 | 28 |
| 710 745 780 | 704 – 787 | LTE Band 13, 17 | Pulse modulation ^{b)} 217 Hz | 0,2 | 0,3 | 9 | 9 |

| Test frequency (MHz) | Band ^{a)} (MHz) | Service ^{a)} | Modulation ^{b)} | Maximum power (W) | Distance (m) | IMMUNITY TEST LEVEL (V/m) | Compliance LEVEL (V/m) (for home healthcare) |
|-------------------------|--------------------------|--|--|-------------------|--------------|---------------------------|--|
| 810 870 930 | 800 – 960 | GSM 800/900, TETRA 800, iDEN 820, CDMA 850, LTE Band 5 | Pulse modulation ^{b)} 18 Hz | 2 | 0,3 | 28 | 28 |
| 1 720 1 845 1 970 | 1 700 – 1 990 | GSM 1800; CDMA 1900; GSM 1900; DECT; LTE Band 1, 3, 4, 25; UMTS | Pulse modulation ^{b)} 217 Hz | 2 | 0,3 | 28 | 28 |
| 2 450 | 2 400 – 2 570 | Bluetooth, WLAN, 802.11 b/g/n, RFID 2450, LTE Band 7 | Pulse modulation ^{b)} 217 Hz | 2 | 0,3 | 28 | 28 |

| Test frequency (MHz) | Band ^{a)} (MHz) | Service ^{a)} | Modulation ^{b)} | Maximum power (W) | Distance (m) | IMMUNITY TEST LEVEL (V/m) | Compliance LEVEL (V/m) (for home healthcare) |
|-------------------------|--------------------------|-----------------------|--|-------------------|--------------|---------------------------|--|
| 5 240 5 500 5 785 | 5 100 – 5 800 | WLAN 802.11 a/n | Pulse modulation ^{b)} 217 Hz | 0,2 | 0,3 | 9 | 9 |

NOTE If necessary to achieve the IMMUNITY TEST LEVEL, the distance between the transmitting antenna and the ME EQUIPMENT or ME SYSTEM may be reduced to 1 m. The 1 m test distance is permitted by IEC 61000-4-3.

^{a)} For some services, only the uplink frequencies are included.

^{b)} The carrier shall be modulated using a 50 % duty cycle square wave signal.

^{c)} As an alternative to FM modulation, 50 % pulse modulation at 18 Hz may be used because while it does not represent actual modulation, it would be worst case.

Maximum single fault steady pressure

Device will shut down in the presence of a single fault if the steady state pressure exceeds -204 cm H₂O for more than 30 seconds.

Note: -204 cmH₂O = -150mmHg

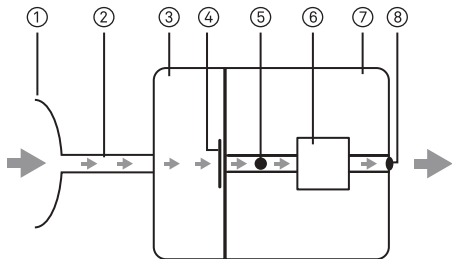

- ① Oral Interface
- ② Tubing
- ③ Saliva Container
- ④ Membrane Filter
- ⑤ Pressure Sensor
- ⑥ Pump
- ⑦ Console
- ⑧ Air Outlet

Pressure Accuracy

Maximum static pressure variation at -54 cmH₂O according to ISO 80601-2-70:

Tested with oral interface: -54cmH₂O ±10%

Measurement system uncertainties

In accordance with ISO 80601-2-70:2015 the measurement uncertainty of the manufacturer's test equipment is:

| | |
|------------------------------------|----------------------------|
| For measurement of static pressure | ± 1 cmH ₂ O |
|------------------------------------|----------------------------|

Note: ISO 80601-2-70:2015 stated accuracies and test results provided in this manual for these items already includes the relevant measurement uncertainty from the table above

Sound

Declared dual-number noise emission values in accordance with ISO 4871:1996

| | |
|--|-------------------------------------|
| Pressure level measured according to ISO 80601-2-70:2015 | 28 dB(A) with uncertainty of 2dB(A) |
|--|-------------------------------------|

| | |
|---|-------------------------------------|
| Power level measured according to ISO 80601-2-70:2015 | 36 dB(A) with uncertainty of 2dB(A) |
|---|-------------------------------------|

Design Life

| | |
|----------------------------|---------|
| Device, power supply unit: | 2 years |
|----------------------------|---------|

| | |
|------------------------|----------|
| Air tubing, connectors | 3 months |
|------------------------|----------|

| | |
|---------------------------|----------|
| Saliva container, Muffler | 6 months |
|---------------------------|----------|

| | |
|--------|-----------------|
| DryPad | Dispose per use |
|--------|-----------------|

| | |
|---------|-------------------------------------|
| General | The patient is an intended operator |
|---------|-------------------------------------|

There are two pivotal studies for iNAP One.

Clinical Pivotal Trial 1

Data from one clinical study showed a clinical response rate of 75% according to the Sher criteria comparing treatment PSG with baseline values.

Clinical Pivotal Trial 2

Data from a second clinical study showed a 52% response to the treatment (see next page). The duration of this study lasted only 28 days. As OSA is a chronic clinical condition, the short duration may not show the durability of the device in the treatment of OSA.

Treatment Response Rate of iNAP One in Clinical Pivotal Trial 2

| | PE Cohort ^{*1} Baseline PSG Study vs Tx ^{*3} PSG Study (n=63) | ITT Cohort ^{*2} Baseline PSG Study vs Tx PSG Study (n= 130) |
|-----------------|---|--|
| Response Rate | 52% (33/63) | 40% (53/130) |
| 95% CI (Wilson) | 40-65 % | 33-49 % |
| P-value * | p = 0.003 | p = 0.129* |

* The performance goal of clinical success rate = 36%

^{*1} PE: Primary Endpoint

^{*2} ITT: Intention-to-treat

^{*3} Tx: Treatment

10 SYMBOL



Warning or caution



Refer to instruction manual



Product manufacturer



Type BF, applied part



Serial number



Batch number



Storage/Transport temperature limits



Storage/Transport humidity limits



Operation/Storage atmospheric pressure limits



Prescription only medical device

IP22

Protection against ingress of solids larger than 12.5 mm and drip water



Do not use if package is damaged



Keep dry



The symbol of the crossed out wheeled bin indicates that the product (electrical and electronic equipment) should not be placed in municipal waste. Please check local regulations for disposal of electronic products.

11 LIMITED WARRANTY

Somnics, Inc. (“Somnics”) warrants that the iNAP One Sleep Therapy System (the “Product“ or “iNAP One”) shall be free from defects in materials and workmanship and will perform in accordance with the Product specifications set forth in the Product instructions for use, for a specified period below:

- iNAP One Console with Battery - 2 years from date of sale to patient
- iNAP Saliva Container & Muffler – 6 months from date of sale to patient
- Accessories Kit (Oral Interface, Tubing Set) - 3 months from date of sale to patient

Should the Product fail to conform to the above warranty, as customers’ sole remedy (and Somnics’ sole liability), Somnics will repair or replace at its discretion, any nonconforming material or part. Warranty claims on defective Product must be made by the initial customer of record, based on assigned serial number, lot number or warranty registration. In order to obtain warranty service, please contact Somnics Customer Service.

Conditions

- This warranty is only available to the initial consumer.
- It is not transferable.

- This is a limited warranty and does not cover:
 - 1.Repairs carried out by any service organization that has not been expressly authorized by Somnics to perform such repairs;
 - 2.Any nonconforming, missing or damage in the serial or lot number;
 - 3.Any damage caused as a result of improper use, improper operating range, accident, neglect, abuse, modification, water ingress, alteration static interference or unstable power supply of the Product;
 - 4.Any damage or contamination due to cigarette, pipe, cigar or other smoke

SOMNICS PROVIDES NO OTHER EXPRESS WARRANTIES WITH RESPECT TO THE PRODUCTS. ALL IMPLIED WARRANTIES WITH RESPECT TO THE PRODUCTS (INCLUDING ANY WARRANTIES OF MERCHANTABILITY OR FITNESS FOR A PARTICULAR PURPOSE) ARE LIMITED IN DURATION TO THE APPLICABLE WARRANTY PERIOD SET FORTH ABOVE (OR, IF LONGER, THE SHORTEST PERIOD ALLOWED BY APPLICABLE LAW).

International Customer Service

TEL: +886-3-5509623

FAX: +886-3-5503633

Email: info@somnics.com

United States Customer Service

TEL: +1-833-766-6427

(+1-833-SOMNICS)

FAX: +1-833-847-2009

Email: contact.us@somnics.com

 Manufactured by

SOMNICS

Somnics, Inc.

5F, No.22, Sec.2, Sheng Yi Rd, Hsinchu Science Park,
Zhubei City, Hsinchu County 30261, Taiwan

TEL +886-3-5509623

FAX +886-3-5503633

Email info@somnics.com

iNAP One is protected by one or more of the following patents.

For detail information, see <http://www.somnics.com/en/legal-and-ip>

Additional patents may be pending in the EU and elsewhere.

P/N 405-099-XXX03

Revised: Sep. 24, 2021